

Narrow Edge Module User Manual

Version V1.0



Thank you for choosing our product. Please read this manual carefully before use.

1.Product Introduction

1.1 Product Overview

This product is a buckle designed for narrow-edge positioning and printing. Made of high-strength ABS material, it features easy installation and precise alignment, meeting various narrow-edge printing requirements.

1.2 Product composition

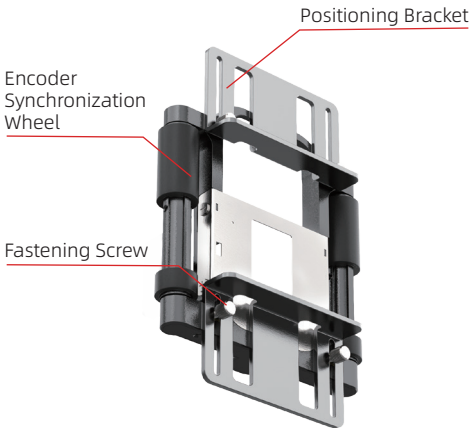

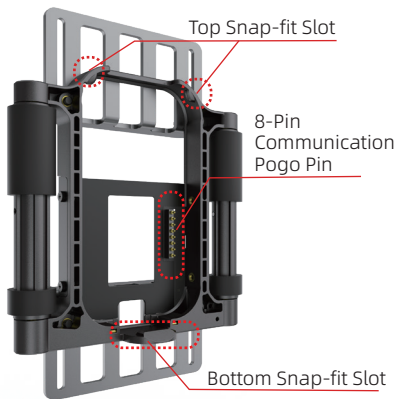

1.3 Product Specifications

Dimensions	L * W * H (10.4*10.4*3.8cm)
Weight	95g
Material	ABS

2. Operating Guide

2.1 Installation Steps

1、 **Align the Slot:** Position the upper part of the buckle into the machine's slot.



2、 **Secure the Buckle:** Firmly press the bottom of the buckle until it fully locks into the printer, ensuring stable installation.



2.2 Removal Steps

1、 **Release the Bottom:** Use your hand to pry open the bottom of the buckle to detach it from the printer.



2、 **Remove the Buckle:** Once loosened, gently lift the buckle upward to complete removal.



2.3 Usage Instructions

1、 Adjust the positioning plate according to the height of the narrow-edged item.



2、 Clamp the positioning plate onto the edge of the printing item, then press and slide to print.

